

BSPP FEMALE - 60° CONE - 90° ELBOW (1)

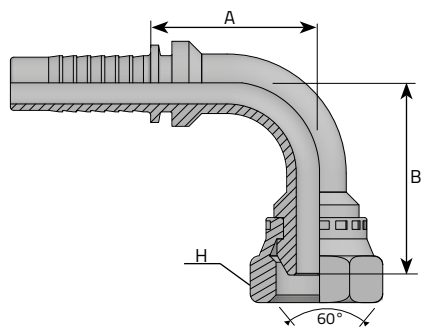

FEMMINA 90° BSPP SV 60°
 FEMELLE 90° BSPP CÔNE 60°
 DKR 90° BOGEN 60° KONUS (BSPP-GEWINDE)
 HEMBRA GIRATORIA A 90° BSPP - CONO 60°

Code	Tube			Thread		Dimensions			Pressure	
	D.N.	Hose	Diam	T	t/1"	H	B	A	Bar	Psi
	Inch	mm	Inch			mm	mm	mm		
F90G0302	-3	3/16"	4.8	1/8"	28	15	29	23	350	5076
F90G0304	-3	3/16"	4.8	1/4"	19	19	29	23	415	6019
F90G0402	-4	1/4"	6.4	1/8"	28	15	29	23	350	5076
F90G0404	-4	1/4"	6.4	1/4"	19	19	29	23	450	6526
F90G0406	-4	1/4"	6.4	3/8"	19	22	32	23	450	6526
F90G0408	-4	1/4"	6.4	1/2"	14	27	30	31.5	450	6526
F90G0504	-5	5/16"	7.9	1/4"	19	19	33.5	31.5	350	5076
F90G0506	-5	5/16"	7.9	3/8"	19	22	35.5	31.5	350	5076
F90G0508	-5	5/16"	7.9	1/2"	14	27	39	31.5	350	5076
F90G0604	-6	3/8"	9.5	1/4"	19	19	37	33	450	6526
F90G0606	-6	3/8"	9.5	3/8"	19	22	38	33	450	6526
F90G0608	-6	3/8"	9.5	1/2"	14	27	42	33	450	6526
F90G0806	-8	1/2"	12.8	3/8"	19	22	43	39	415	6019
F90G0808	-8	1/2"	12.8	1/2"	14	27	45	39	415	6019
F90G0810	-8	1/2"	12.8	5/8"	14	28	45	39	415	6019
F90G0812	-8	1/2"	12.8	3/4"	14	32	51	39	415	6019
F90G1008	-10	5/8"	16	1/2"	14	27	54	49	350	5076
F90G1010	-10	5/8"	16	5/8"	14	28	54	49	350	5076

BSPP FEMALE - 60° CONE - 90° ELBOW (2)

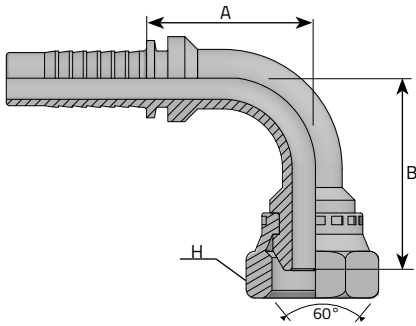

FEMMINA 90° BSPP SV 60°
 FEMELLE 90° BSPP CÔNE 60°
 DKR 90° BOGEN 60° KONUS (BSPP-GEWINDE)
 HEMBRA GIRATORIA A 90° BSPP - CONO 60°

Code	Tube		Diam	T	Thread	Dimensions			Pressure	
	D.N.	Hose				H	B	A	Bar	Psi
	Inch	mm	Inch	t/1"	mm	mm	mm			
F90G1012	-10	5/8"	16	3/4"	14	32	56	49	350	5076
F90G1208	-12	3/4"	19	1/2"	14	27	56	53.5	350	5076
F90G1210	-12	3/4"	19	5/8"	14	28	56	53.5	350	5076
F90G1212	-12	3/4"	19	3/4"	14	32	59	53.5	350	5076
F90G1216	-12	3/4"	19	1"	11	38	65	53.5	350	5076
F90G1612	-16	1"	25.4	3/4"	14	32	72	68.5	280	4061
F90G1616	-16	1"	25.4	1"	11	38	72	73	280	4061
F90G1620	-16	1"	25.4	1.1/4"	11	50	80	73	280	4061
F90G2020	-20	1.1/4"	31.8	1.1/4"	11	50	93	89	210	3046
F90G2024	-20	1.1/4"	31.8	1.1/2"	11	55	98.5	89	210	3046
F90G2424	-24	1.1/2"	38.1	1.1/2"	11	55	114	101	185	2683